

## R22i Mounting Instructions - Static Alignment (Standard Mounting)

Verify that you received the following items:

- Encoder
- Cover
- Slide gapping mechanism (installed in encoder)
- Setscrew wrench (installed in encoder)
- (2) 2-56 Hex Socket Screws

**CAUTION ---- ESD Precautions Apply ---- CAUTION**

### Motor Preparation

Energize motor U winding with sufficient voltage and current to lock motor rotor. Motor shaft will return to same position when rotated in either direction by hand.

### Encoder Preparation

**IMPORTANT! Do not apply power to the encoder at this time.**

Verify that the slide and the setscrew wrench are installed in the encoder. Setscrew wrench goes through a slot in the encoder housing to engage with hub setscrew, which allows rotating the hub/disk assembly  $\pm 20$  degrees to align the commutation U channel and Index to the locked rotor of the motor. [\(Figure 1\)](#)

#### Step 1

Align encoder mounting tabs with mounting holes on the motor. Slide encoder onto the motor shaft until the encoder is resting on the motor endplate. [\(Figure 1\)](#) If encoder hub does not slide easily, check that the hub setscrew does not extend into the hub bore or that burrs are not present on the motor shaft. If either exists, remove encoder and correct fault.

#### Step 2

Mount the encoder to the endplate by installing the supplied hex socket mounting screws. Secure mounting screws to 12 oz-in torque. [\(Figure 2\)](#)  
Threadlocker 222 may be applied to screw threads to prevent screw from unthreading during operation.

#### Step 3

Install test cable and apply power to the encoder. Use an appropriate method to measure the commutation outputs. [\(Figure 3\)](#) shows a method using LED's to represent the output states.) Rotate hub with the setscrew wrench until U commutation output transitions. If the transition does not occur, rotate hub in the opposite direction until the channel U transition occurs. Rotate hub in the opposite direction until U commutation output transitions again. Rotate hub to the midpoint of the two channel U transition positions. Secure the hub setscrew with 20 oz-in torque. Bonding of encoder hub is recommended for high speed or accel/decel operation of motor. [\(Bonding and Debonding Methods\)](#)

**CAUTION: Over tightening the setscrew will cause Brinelling of the shaft making it difficult to remove encoder.**

#### Step 4

Remove the hub setscrew wrench and slide from the encoder.

Change: Initial Release

	Release-no.		Created	Responsible	Released	Version	Rev.	Sheet	Page
	<b>23110</b>	Name	Dupuis	Dupuis	Setbacken	<b>D00548175 - 00 - A - 01</b>			1/
		Date	05/11/2005	07/13/2006	07/13/2006	Document no.			3

This document is the property of RENCO Encoders and is submitted in confidence. Disclosure, reproduction or publication without written authorization is prohibited.

**Step 5**

Verify proper commutation alignment by rotating motor shaft slightly in either direction. [\(Figure 3\)](#) Logic level will remain at the same logic state when motor shaft returns to the locked rotor position. If this does not occur, reinstall the slide and setscrew wrench. Loosen hub setscrew and go to Step 3.

**Step 6**

Bond hub to motor shaft using recommended bonding method. [\(Bonding and Debonding Methods\)](#)

**Step 7**

Remove test cable and install cover. [\(Figure 4\)](#) Install cable assembly. Encoder is now ready for operation.

**Encoder Removal**

- Remove cable assembly.
- Remove cover.
- Rotate hub until setscrew is visible in the slot in the encoder housing.
- Install slide into the encoder housing.
- Install hub setscrew wrench.
- Loosen hub setscrew (If hub has been bonded, see [\(Bonding and Debonding Methods\)](#))
- Remove encoder mounting screws.
- Remove encoder.

FIGURE 1

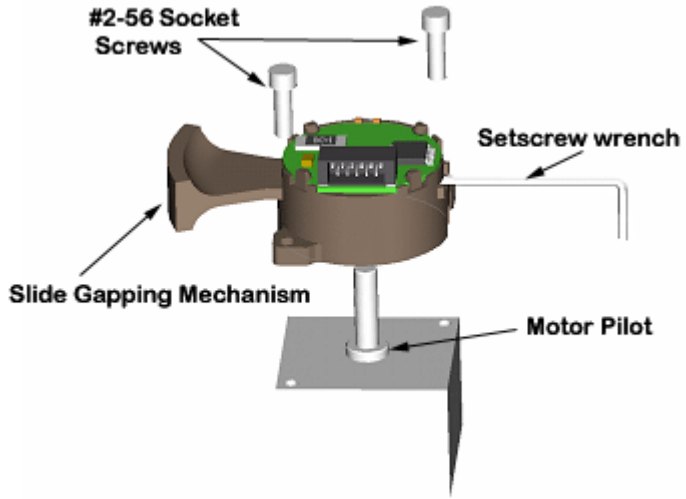
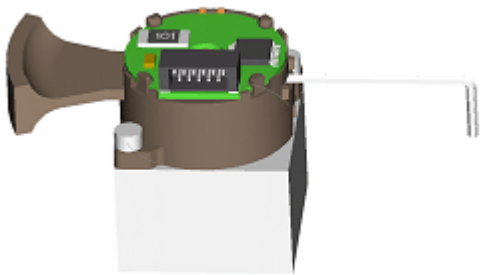

FIGURE 2



	Release-no.		Created	Responsible	Released	Version	Rev.	Sheet	Page
	<b>23110</b>	Name	Dupuis	Dupuis	Setbacken	<b>D00548175 - 00 - A - 01</b>			2/
		Date	05/11/2005	07/13/2006	07/13/2006	Document no.			3

FIGURE 3



This document is the property of RENCO Encoders and is submitted in confidence. Disclosure, reproduction or publication without written authorization is prohibited.

FIGURE 4

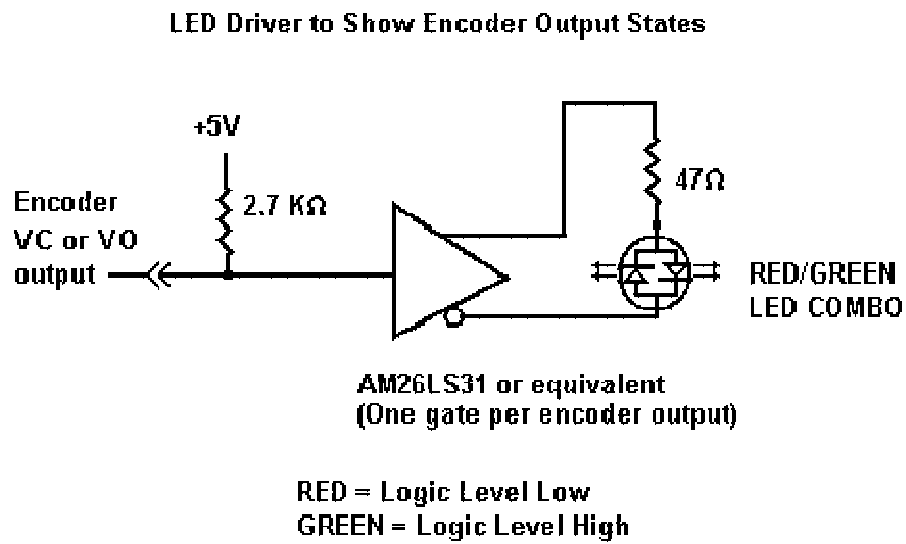

[RETURN TO TOP](#)

	Release-no.		Created	Responsible	Released	Version	Rev.	Sheet	Page
	<b>23110</b>	Name	Dupuis	Dupuis	Setbacken	<b>D00548175 - 00 - A - 01</b>			3/
		Date	05/11/2005	07/13/2006	07/13/2006	Document no.			3