

**R35i - Data Only
Mounting instructions**

Verify that you received the following items:

- Encoder
- Cover
- Setscrew wrench
- M2.5 or #2-56 Torx Head Mounting Screws with Captive Washer for C or H option
- M2.5 or #4-40 Socket Head Cap Screws for C4 or H4 option

Before you begin:

The following instructions are for random index location with respect to the shaft. If the index output needs to be aligned to the shaft, please contact factory for appropriate method for your motor type.

CAUTION ---- ESD Precautions Apply ---- CAUTION

Encoder Preparation

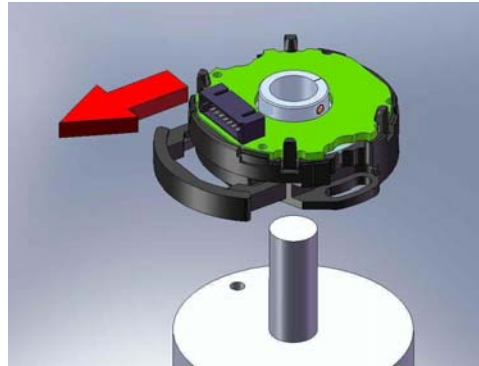

Verify that the slide lock mechanism is fully extended. If needed, apply thread locker to the mounting holes.

Step1

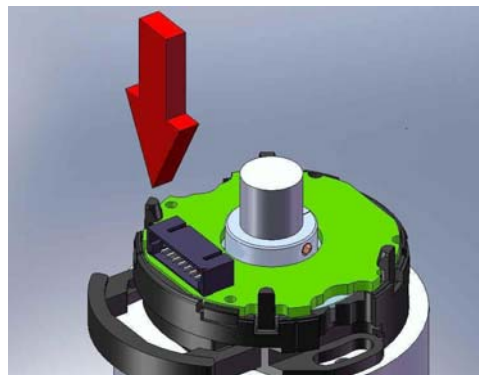

Slide encoder onto the motor shaft.

Step 2

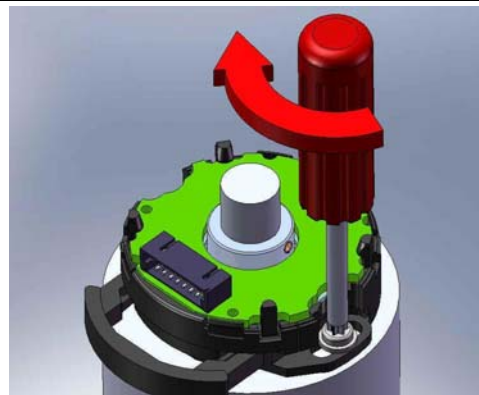

Install mounting screws finger tight, then torque to 35-40 oz-in.

This document is the property of RENCO Encoders and is submitted in confidence. Disclosure, reproduction or publication without written authorization is prohibited.

542543

Change:

	Release-no.		Created	Responsible	Released	Version	Rev.	Sheet	Page
	07698	Name	Powell		Rhodes	D548176 - 01 - A - 01			1/
		Date	19.11.2009		14.12.2009	Document no.			2

Step 3

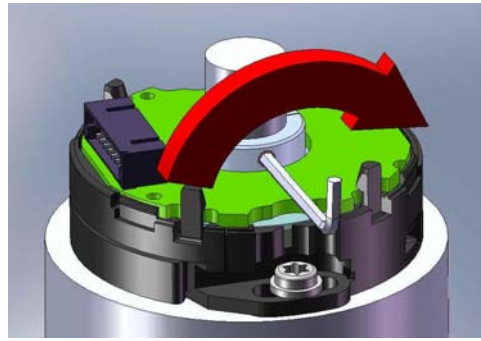

**Torque set screw to 20 oz-in.
Bond hub to shaft for high
acceleration or deceleration
applications.**

Step 4

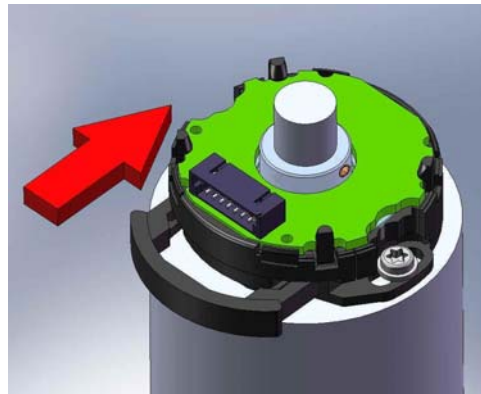

Push in slide lock mechanism.

Step 5

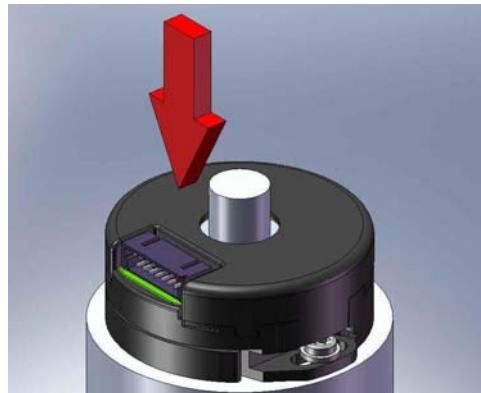

Install cover.

Step 6



Install cable.

	Release-no.		Created	Responsible	Released	Version	Rev.	Sheet	Page
	07698	Name	Powell		Rhodes	D548176 - 01 - A - 01			2/
		Date	19.11.2009		14.12.2009	Document no.			2